



# INTRODUCTION

This information is intended as an installation guide for Metalcraft Tiles and accessories and provides guidance for the fixing of battens and tiles, and the cutting, and forming of ridges, hips and valleys. It does not describe the roof structure such as rafter size and spacing, nor the bracing requirements of the roof.

It is the builder's task to erect framing and timberwork and install valley boards; however it is the tiler's responsibility to check that the framing is accurate and sufficient before installation. All roof structure and bracing requirements must be installed to comply with the NZS 3604 2011. Alternatively the structure should be designed by a Design Engineer.

## SITE STORAGE & HANDLING

Metalcraft Tiles and accessories are delivered on pallets which should remain strapped together and stored under cover where damage will not occur. Avoid stacking pallets on top of each other wherever possible, particularly where boxes of flashing accessories are included.

When delivering to site, it is recommended that pallets be protected by tarpaulins. In wet conditions avoid leaving orders unprotected on site any longer than three days as marks or staining may occur if water is trapped between tiles and allowed to dry.

Should this occur, cleaning with soapy water should get rid of any marking, however prevention is definitely the best policy.

Pallets and battens should be deposited as close to the building as possible to minimise tile handling and foot traffic, and wherever possible ensure there is clean dry access to the roof to avoid risk of slipping and any marking of laid tiles.

If scratching on the painted surfaces occurs during transit or installation, all tiles and accessories with visible marks (eg: visible from three metres or more), must be replaced.

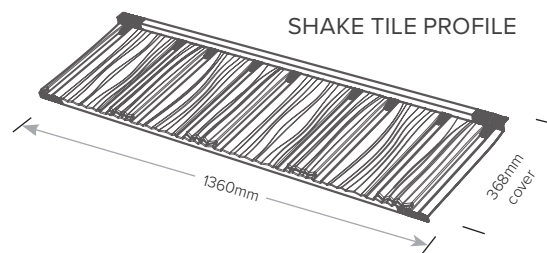
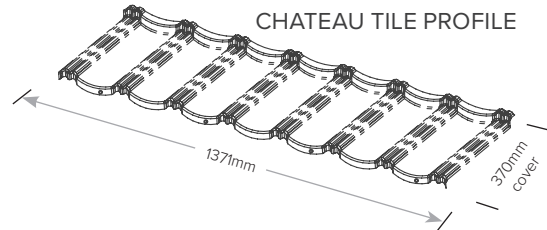

## INSTALLATION GETTING STARTED

Underlay is laid over the rafters with battens on top; this creates an air space between the underlay and the tile. Permeable self supporting underlay must be installed on all new roofs and should be installed horizontally with a minimum overlap of 150mm. Wherever possible laps should occur beneath the battens.

At the ridge line the underlay should protrude 25mm past the upper edge of the tiling batten on either side of the ridge board/batten.

At the eave line, the paper must extend over the fascia board by 30mm and the tile should overhang the fascia by 40mm (fig. 1, page 2).





# TILING BATTENS

Battens should be no less than 50mm x 40mm for 600mm-900mm rafter spacings or 50mm x 50mm for 900mm-1200mm spacings. For both rafter spacings, 50mm x 40mm battens must be used for ridging, gables and hips or else the flashing tile will sit too high and expose the turned up tile.

A minimum penetration of 20mm is required when nailing at the intersection of rafter/trusses and battens. All joints should be located at the centre of the rafter; however there must be no more than two adjacent joints on any one rafter or truss (fig. 2).

When filling in sides to meet hips/valleys, short end battens must span a minimum of two trusses. Battens should be mitre cut where they intersect with the hip and valley battens.

If fascia board is 40mm, the bottom course of tiles can be nailed directly onto this. However if fascia is less than 40mm, or if it is a metal fascia, a batten should be installed directly behind the fascia as fixing for the eave tiles and should be fixed in place prior to paper being laid.

Battens should be laid from the lowest part of the roof upwards using pin out nails to locate the front edge of the batten.

Metalcraft Tiles require a pin out measurement of 370mm for Chateau and 368mm for Shake (fig. 3). Base line behind fascia should be aligned using a tight string line to ensure batten rows up the roof are straight and accurate. Once base line of pin out nails is achieved, pin up each rafter using a pin out stick at the required spacing.

## USEFUL TIPS FOR PINNING OUT:

- Tap nails into left or right quarters of the rafter, this will leave the centre of the rafter clear for passage of timber cutting blade when cutting joints and will reduce chances of blade hitting nails causing risk to operator and blunting the saw blade.
- Low pitch roofs tap pin outs into rafter approx 20mm, for steep pitches tap nails into rafter 30mm or more to stop nails laying over when walked on by fixer.

FIG.1 PAPER OVERHANG

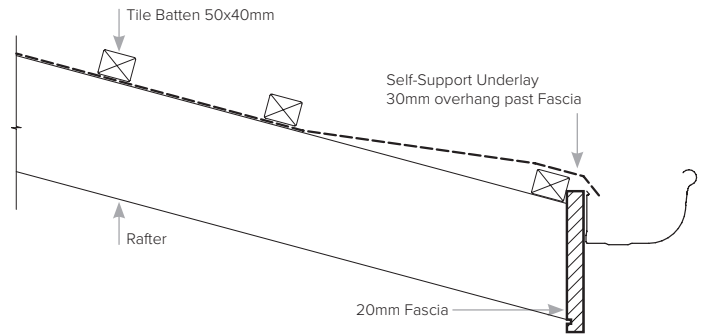

FIG.2 BATTEN LAYOUT

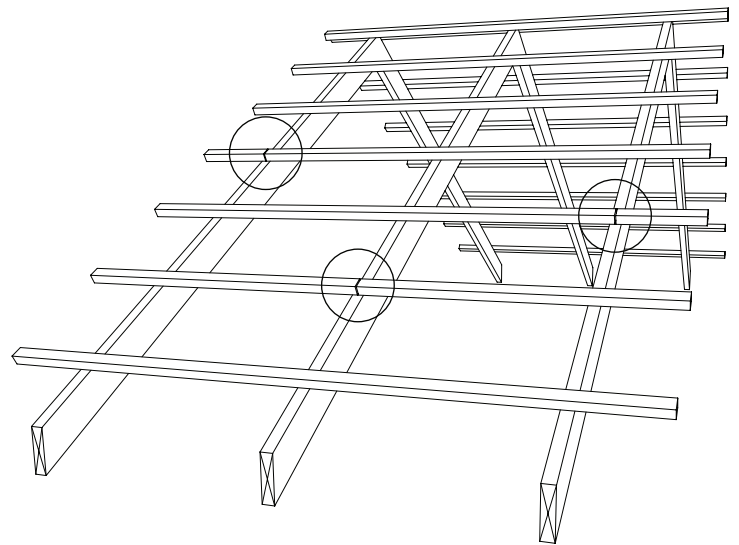
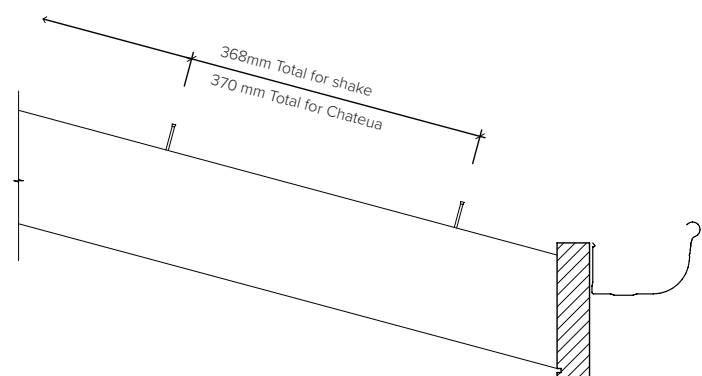

FIG.3 PIN OUT SPACING



# FIXING BATTENS

The below table aligns with NZS3604: 2011 (table 10.12)

Light roof Cladding		Maximum spacing and fixing in the following wind zones									
		<i>Low</i>		<i>Medium</i>		<i>High</i>		<i>Very High</i>		<i>Extra High</i>	
Tile Batten Size	Max Span (Centres)	Spacing	Fixing	Spacing	Fixing	Spacing	Fixing	Spacing	Fixing	Spacing	Fixing
All dimensions in (mm)											
50x40	900	370	<b>R</b>	370	<b>R</b>	370	<b>S</b>	370	<b>S</b>	370	<b>T</b>
50x50	1200	370	<b>R</b>	370	<b>S</b>	370	<b>T</b>	370	<b>T</b>	370	<b>T</b>

Fixing Type	Nail Fixing to rafter junction	Alternative Fixing capacity (kN)
<b>R</b>	<b>90 x 3.15 gun nail</b> 1 Per batten to rafter junction	0.55
<b>S</b>	<b>90 x 3.15 gun nails</b> 2 Per batten to rafter junction	0.8
<b>T</b>	<b>10g self - drilling screw, 80mm long</b> 1 Per batten to rafter junction	2.4

# BARGE/GABLE SET OUT

Once the horizontal battens have all been laid in and butted up to the barge/gable boards, install the vertical battens the flashings will be fixed to.

Set outs for barge/gable ends will vary slightly depending on the flashing type being used and thickness of the barge board.

When working with standard barge board (20mm), most flashings require 70mm from the outside of the batten to the outside of the barge board.

Note: the following details are common to all tile profiles.

ANGLE CAPS ON GABLES

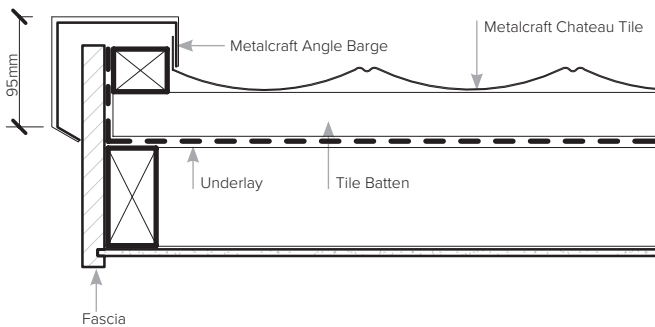

FOLDED BARGE FLASHINGS ON GABLES

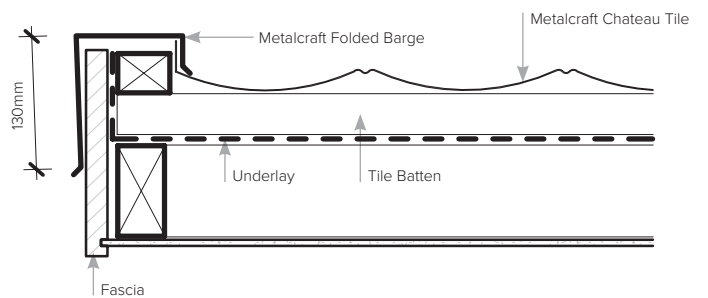

# RIDGE BATTEN SET OUT

If the rafter length prevents using a full course of tiles, then the top course will have to be cut and bent to suit. Thus requiring the spacing of the top batten to be less than the standard measurement.

For Angle Ridge Caps the base battens on the ridge should be set down 25mm from each side of the apex. Another line of battens should be fixed on top of the ridge battens and the 25mm gap should be maintained.

For pitches over 35 degrees bring battens 5-10mm closer to prevent lifting of caps.

For Barrel ridge tiles follow the same set out except that the gap should be reduced to 10mm from the Apex. Pitches over 35mm battens should touch at bottom inside edge to prevent lifting of caps.

Folded flashings also require battens to be set 25mm either side of the apex, however instead of another row of battens, a 100mm x 20mm Ridge Board should be fixed at the apex.

## ANGLE CAPS ON RIDGE

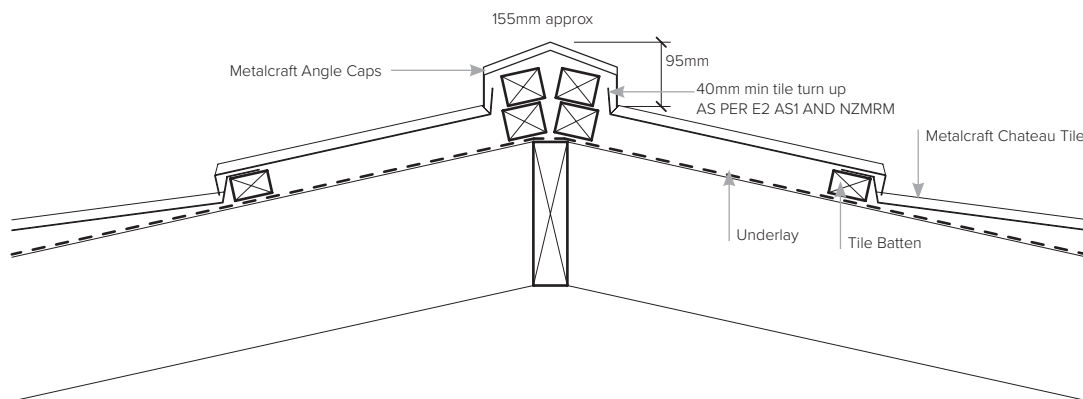

## FOLDED RIDGE

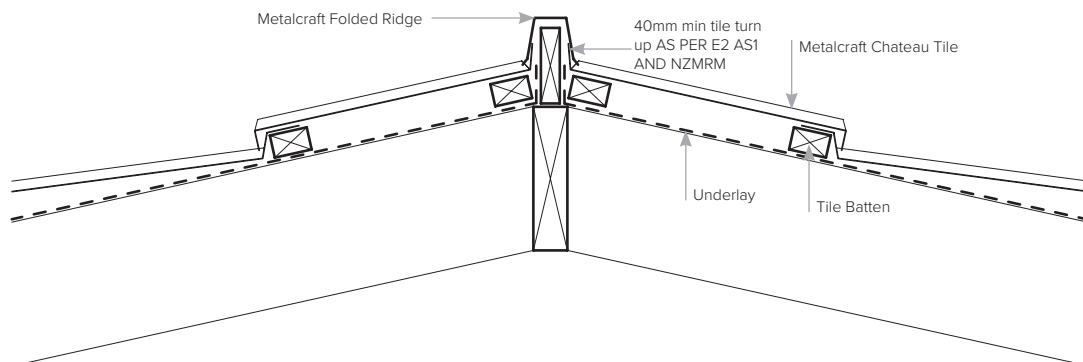

Chateau, tile illustrated, above. For complete installation details for Chateau and Shake, these can be downloaded from [www.metalcraftgroup.co.nz](http://www.metalcraftgroup.co.nz)

# VALLEY BOARDS

Valleys are the responsibility of the builder and should be formed by fixing 150mm x 25mm rough sawn timber valley boards in between jack rafters/trusses which must sit flush with the top of the rafters.

The outer edge of the valley board must be set to a minimum of 150mm from the centre line of the valley. It is important to ensure valley boards are not only straight but strongly secured as they are often a main point of access for the tilers.

Valley guard paper should then be laid on the valley boards before laying the valley trays on top. The valley can be fastened by nails bent over its top lip. The valley cannot be penetrated by fixings.

Where joins occur, the overlap should be no less than 200mm, and undersealed.

The top of the valley should be turned up to approximately 80-90mm, or at least to the height of the ridge batten and nailed at the top of the turn up.

Battens should butt up hard against the valley tray.

The tile edge should be bent down approximately 30mm into the valley but remain a minimum of 5mm from the valley floor.

The gap between tiles on opposing sides of the valley must be a minimum of 80mm to allow an adequate flow of water.

For roof pitches over 40 degrees the valley tray will need to be folded at a deeper angle.

A flatter angle is required for 15 degree pitch or less as standard trays are made to accommodate pitches of 20-35 degrees.

NB: It is the responsibility of the fascia installer to cut a recess in the back of the fascia/ gutter to allow the valley to discharge into the gutter. If a wooden fascia then the builder must ensure this is done otherwise the valley cannot sit straight.

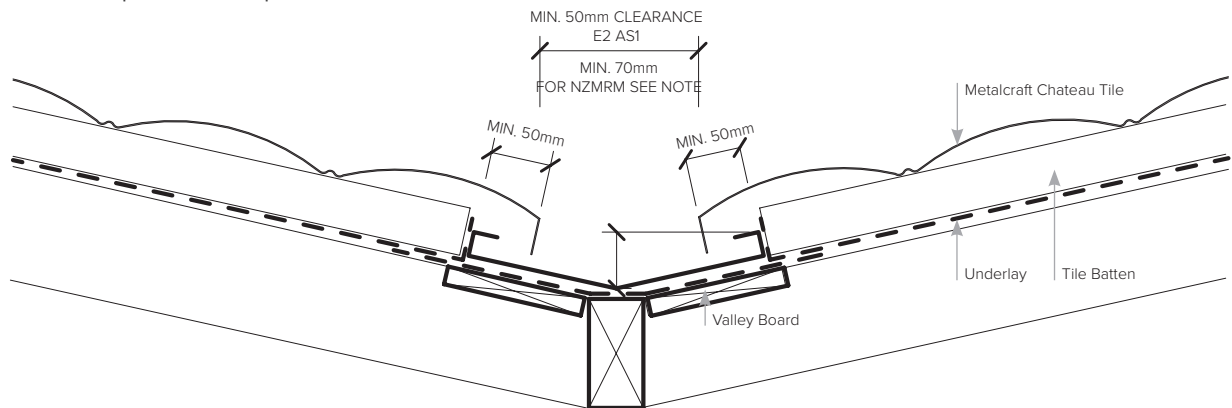

Chateau, tile illustrated, above. For complete installation details for Chateau and Shake, these can be downloaded from [www.metalcraftgroup.co.nz](http://www.metalcraftgroup.co.nz)

# WALL TO ROOF JUNCTIONS & Z-FLASHING

Wherever a wall extends past the roof, a plastic diverter or tray flashing is required at the end of the roof to ensure water is diverted into the gutter. These should be fitted prior to the side flashings and sit over the top of the first batten at the same pitch as the tile.

Walls should be nogged at the correct height prior to installation of side flashings. This should be 90mm from top of truss to bottom edge of the nog and should be flush with outside edge of stud.

Side or Z flashings are then fitted and should overlap the diverter. It is the builders responsibility to tape the top edge onto the building paper to seal.

Cladding should go no lower than the highest fold line on the Z-flashing.

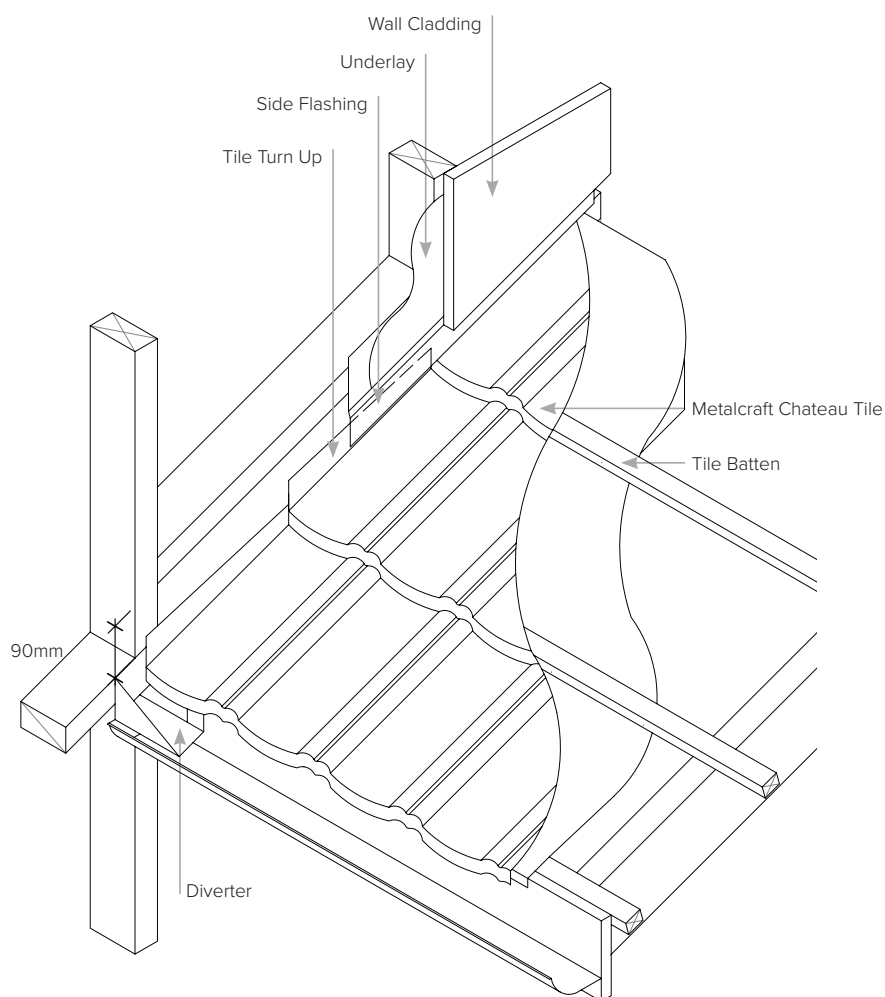



SIDE FLASHING

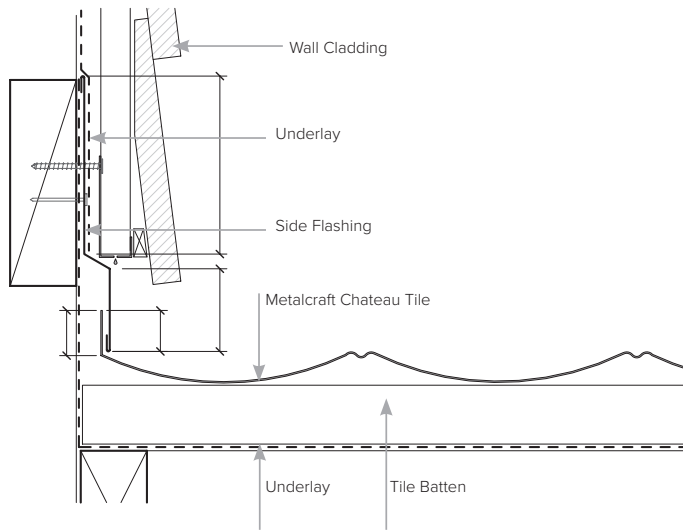

HEAD APRON

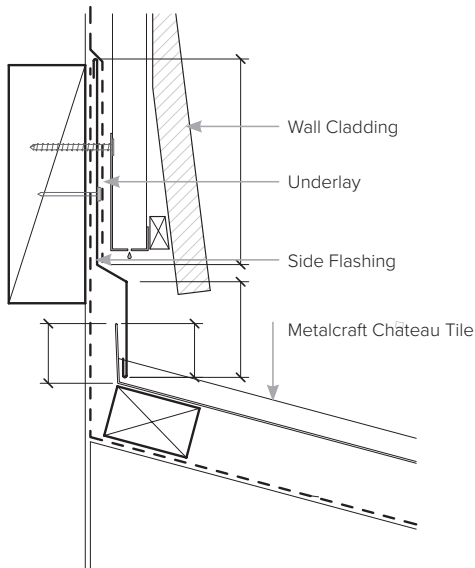

SECRET GUTTER

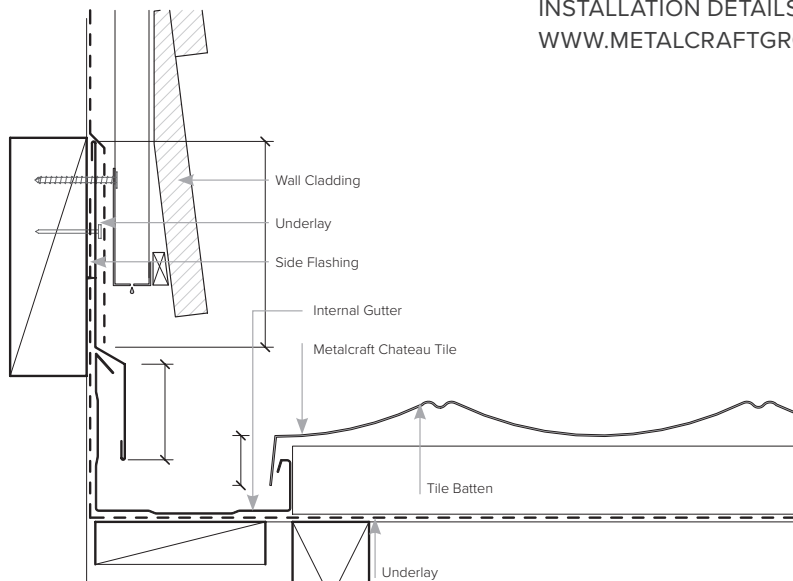

FOR FLASHING DIMENSIONS  
PLEASE REFER TO METALCRAFT  
INSTALLATION DETAILS  
[WWW.METALCRAFTGROUP.CO.NZ](http://WWW.METALCRAFTGROUP.CO.NZ)

# LAYING TILES

When laying full tiles in the main roof area it is advisable to work from the apex to the eave line, and **left to right**. This helps reduce the risk of tile damage from foot traffic.

All full tiles must be laid out first. The first full tile should be laid 150mm from the hip and begin at the second row from the top. Tiles on the top row are folded and cut to suit the remaining gap. The top edge is folded to form a 50mm up stand and then nailed to the ridge or battens.

Hip/Gable tile measurements should then be taken allowing for a 40mm turn up on the ends of tiles. These are then cut and folded on the ground and then placed in position on the roof. Take care when installing ridge, hip and barge flashings to ensure lines are straight and weather protection is achieved.

The bottom course tile must overhang the fascia by a minimum of 30mm but 40mm is recommended. However in cases of a difficult top course tile size the tiler may adjust this measurement between 30-60mm as long as it does not infringe on the function of the gutter.

The Barrel and Angle Cap tiles will require bending on site to form the barge flashings. End trim or stop ends need to be formed from an off cut of the tile to fill the gap at the bottom end of the barges/hips.

Ideally (taking into account the prevailing conditions) laps should face away from line of sight except in the case of the Shake tile which will only lay in one direction.

Tile cuts and bends should be as straight as possible to allow a true line for flashings.

## METALCRAFT SHAKE TILE OVERLAP

NB: Shake tile can lap in both directions

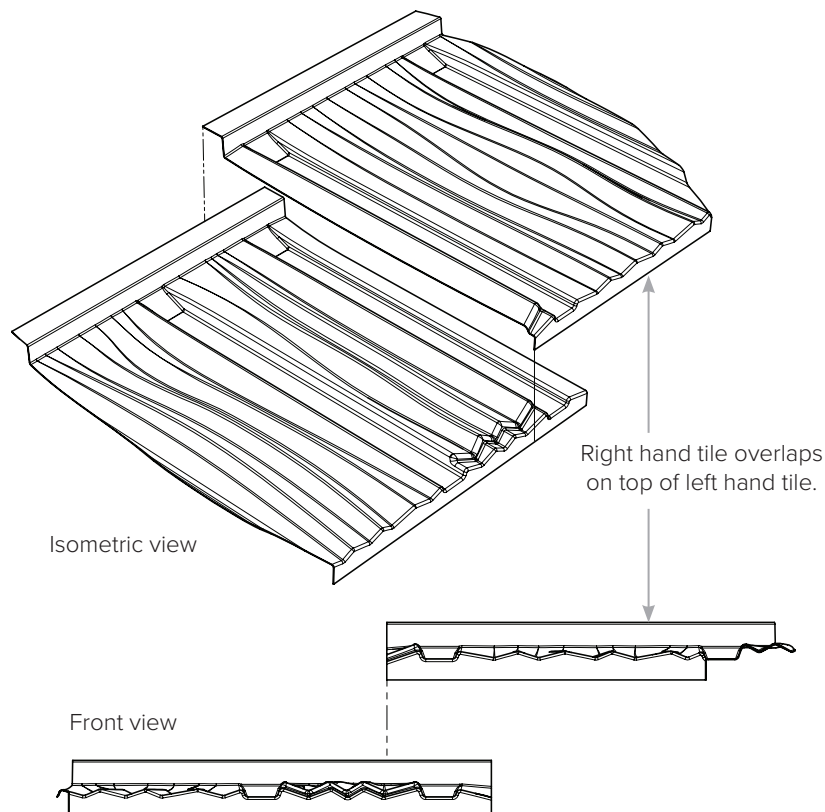

## NAILING PATTERNS AND FASTENING DETAILS

Metalcraft Tiles should be fixed with 50mm x 2.8mm flat head nails. For dark coloured tiles use hot dipped galvanized black coated. When installing light coloured tiles straight silver galvanized nails should be used as they will be less conspicuous.

Nails on all tiles except the bottom course should be driven through the front edge of the rib of the tile, offset from the centre line so the head of the nail sits flush against the tile.

Fastening on the top course and tiles intersecting hips is completed by driving nails through the turn up into the ridge and or battens running up the barge.

Only the bottom course of the tiles should be nailed through the top face, on the side of the rib using the same nail except with a rubber washer attached. Ensure these nails run in straight lines around the eave line.

### CHATEAU TILE - FASTENING DETAILS

Bottom Course pattern - 50 x 2.8 coloured with neoprene washer seal

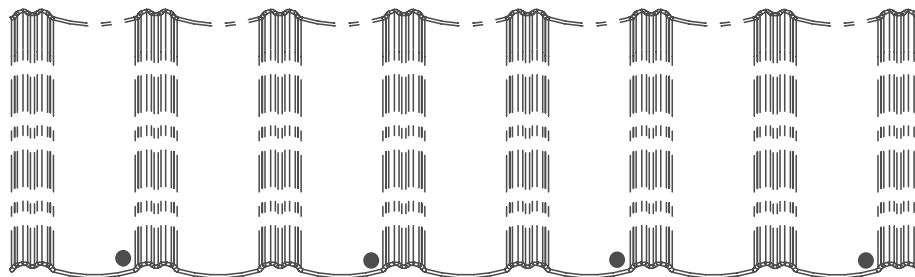

Main roof area pattern - 50 x 2.8 Black or Galv nails

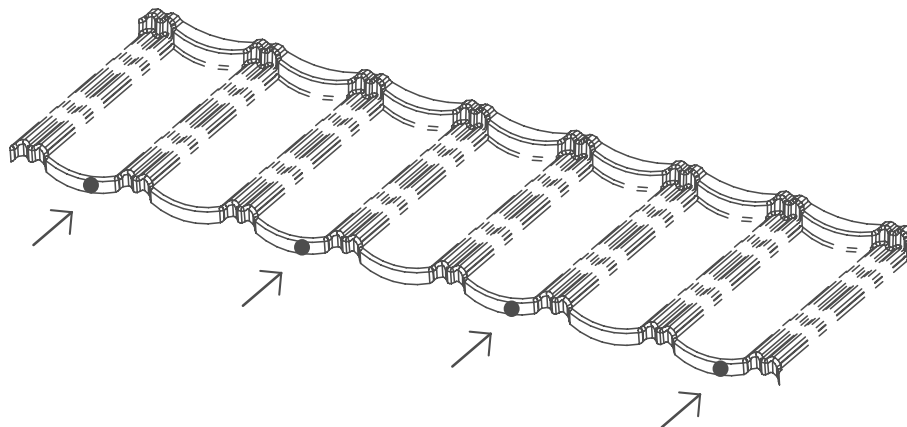

## SHAKE TILE - FASTENING DETAILS

Bottom Course pattern - 50 x 2.8 coloured with neoprene washer seal

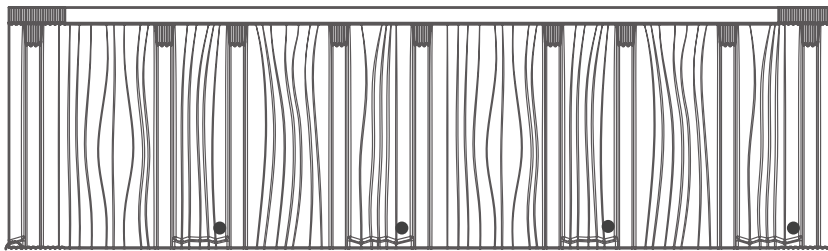

Main roof area pattern - 50 x 2.8 Black or Galv nails

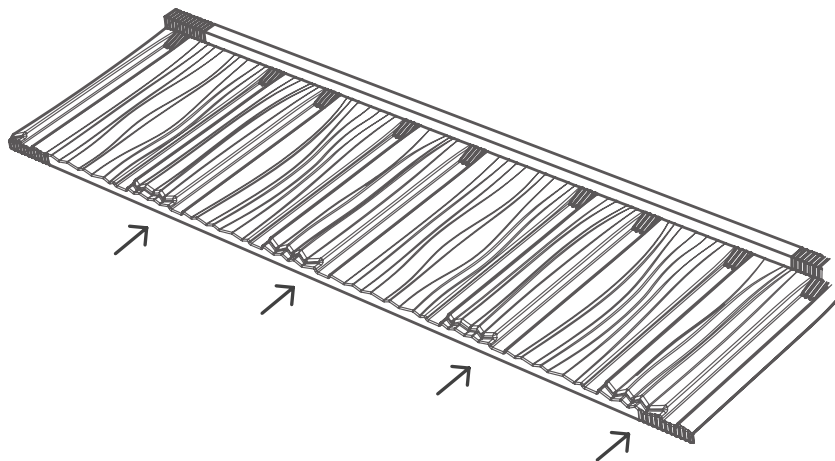

# LAYING RIDGES AND HIPS

For folded flashings the ridge/hip board should be formed from 100mm x 25mm timber on edge and project 50mm, plus batten height, above the rafters to provide fixing for the flashing.

The tiles must be turned up a minimum of 40mm against the battens, hip board or any other vertical/inclined surface. The cap tile or flashing should cover the tile turn ups by a minimum of 35mm. To ensure a watertight joint and prevent ingress of water, a tight fit is required between the tile and the ridge cap.

Folded flashings should overlap 100mm and joints should be undersealed with sealant. Wherever possible laps should be away from the line of sight (excluding hips).

Hip end caps should be made from an offcut and riveted inside the front edge.

## HIP END CAPS

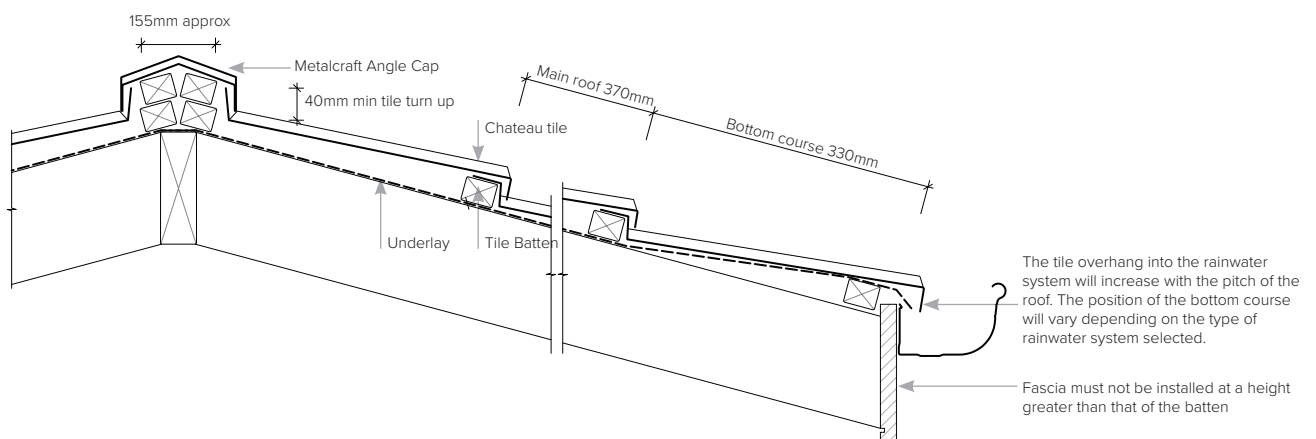
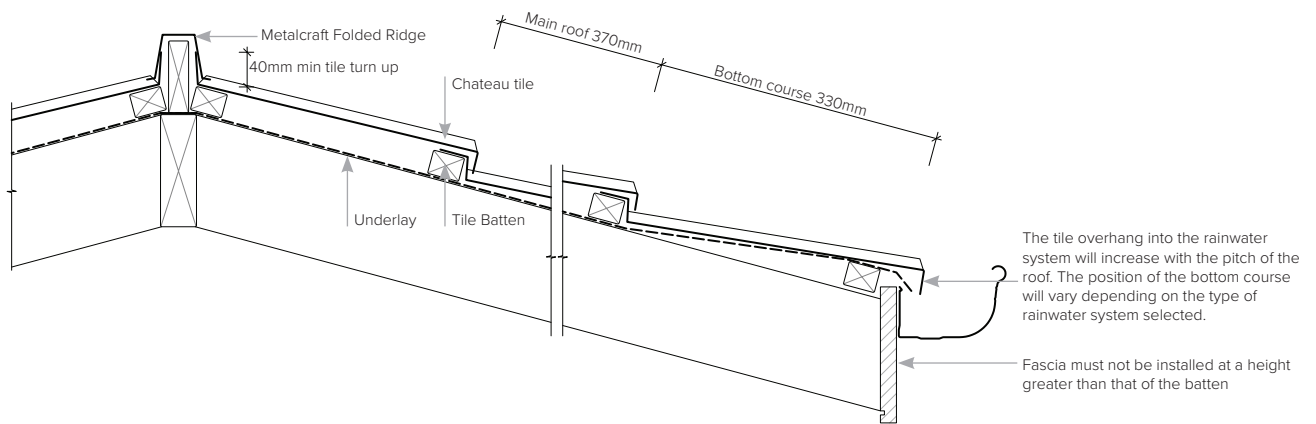



# LAYING BARGE / GABLES

An additional batten running parallel with the bargeboard is fixed on top of the tile battens. The thickness of the batten and barge combined must be 65mm. The top of the barge board must be finished no lower than the bottom of the tile batten or no higher than the top of the tile batten running up the barge.

A 90 degree fold will need to be made on one side of the flashing tile for the turn up to sit under so the fit is tight.

End caps for Angle ridge tiles should be made from an off cut and riveted inside the front edge with an end slot cut to sit on the barge board.

Joints should also be undersealed and fastened with coloured rivets to match the roof.

## STANDARD FLASHINGS

Flashings come in 1.5m lengths only. Painted flashings come in 2m lengths, but can be longer if required.

### FOLDED BARGE

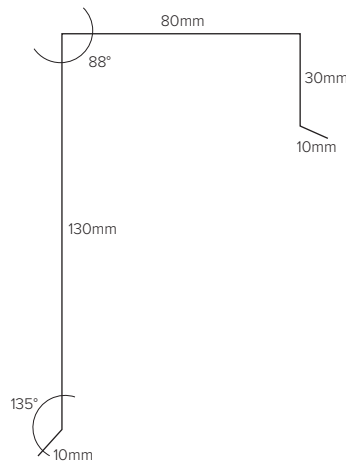

### FOLDED SIDE FLASHINGS

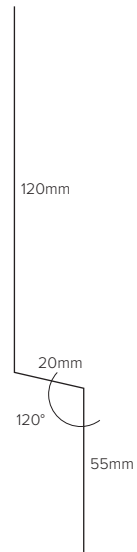

### BARGE & GABLE END CAPS



### FOLDED RIDGE

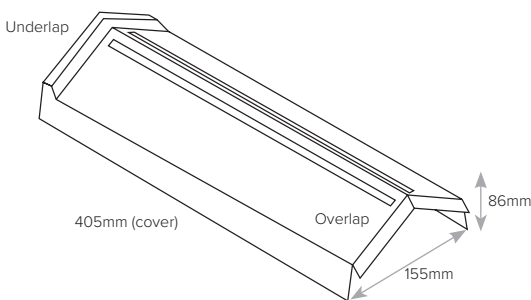
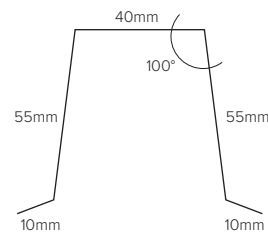

### FOLDED VALLEY



FOR VALLEY GUTTER DIMENSIONS AS PER TABLE 8 OF E2 AS1.

OR FOR ALTERNATIVE VALLEY GUTTER DESIGN REFER TO THE NZMRM CODE OF PRACTICE.

# GENERAL NOTES

- Edge protection is required when working at any height that is deemed unsafe
- Roofs should only be installed by authorised metal tile installers, and are to be checked prior to installation for correct timberwork and compliance on edge fall/ scaffold requirements
- Fixers to wear soft soled sandshoes for traction but also to minimise wear and tear on tiles during installation.
- Fixers should use 'bull horns' so that battens do not lean on metal fascia or gutter, and remain upright safely.
- Where lower roof is installed prior to installation of cladding and painting, the main contractor should sign off to protect installer against any liability from future damage caused by foot traffic from other trades.
- Similarly, when a roof is completed by fixers, a final quality check should be undertaken by a supervisor.
- Fixers are responsible for leaving a site clean and tidy upon completion; left over tiles and battens should be stacked neatly (or returned to yard if possible), and paper and tile wastage should be disposed of. This includes roofs completed in stages.
- Contractors to notify supervisor of any left over product on site.

## TOOLS YOU WILL NEED

---

- Drill
- Cutting Saw
- Pin out nails (Brights 90mm)
- Pedal Operated Bender
- Left / Right Hand snips
- Builders Ruler
- Tape Measure
- String Line
- Builders Pencil
- Pop riveter
- Nail gun (Paslode 90x3.15)
- Top Course Bender
- Guillotine
- Green snips
- Hammer
- Silicone Gun
- Stanley Knife

# BRANCHES

## Whangarei

42-44 Rewa Rewa Road, Whangarei  
09 470 0870  
sales.whangarei@metalcraftroofing.co.nz

## Auckland Hobsonville

25 -27 Westpoint Drive, Hobsonville, Auckland  
09 444 1813  
orders.ns@metalcraftroofing.co.nz

## Auckland East Tamaki

24-26 Trugood Drive East Tamaki, Auckland  
09 273 2820  
orders.akl@metalcraftroofing.co.nz

## Hamilton

9 Earthmover Cres, Burbush, Hamilton  
07 849 3807  
sales.hamilton@metalcraftroofing.co.nz

## Tauranga

42 Poturi St, Tauriko, Tauranga  
07 575 7032  
sales.tauranga@metalcraftroofing.co.nz

## Rotorua

15 Monokia Street, Rotorua  
07 350 1138  
sales.rotorua@metalcraftroofing.co.nz

## New Plymouth

218 De Havilland Drive, Bell Block, New Plymouth  
06 755 2113  
sales.newplymouth@metalcraftroofing.co.nz

## Palmerston North

76 Malden Street, Palmerston North  
06 358 9149  
sales.palmerston@metalcraftroofing.co.nz

## Hastings

1454A Omahu Road, Hastings  
06 873 9020  
sales.hastings@metalcraftroofing.co.nz

## Wellington

201 Gracefield Rd, Seaview, Lower Hutt  
04 566 2253  
orders.wgtn@metalcraftroofing.co.nz

## Christchurch

85 Columbia Ave, Hornby, Christchurch  
03 349 7350  
sales.christchurch@metalcraftroofing.co.nz

## Cromwell

20 McNulty Road, Cromwell  
03 445 4180  
sales.cromwell@metalcraftroofing.co.nz



Metalcraft Roofing are members of the Roofing Association, New Zealand and the New Zealand Metal Roofing Manufacturers Incorporated (NZMRM).



For more information on Metalcraft Roofing visit:  
[www.metalcraftgroup.co.nz](http://www.metalcraftgroup.co.nz)  
Metalcraft Roofing is part of United Industries Ltd.  
For more information on United Industries visit:  
[www.unitedindustries.co.nz](http://www.unitedindustries.co.nz)